

A48 ACOUSTICAL WALL

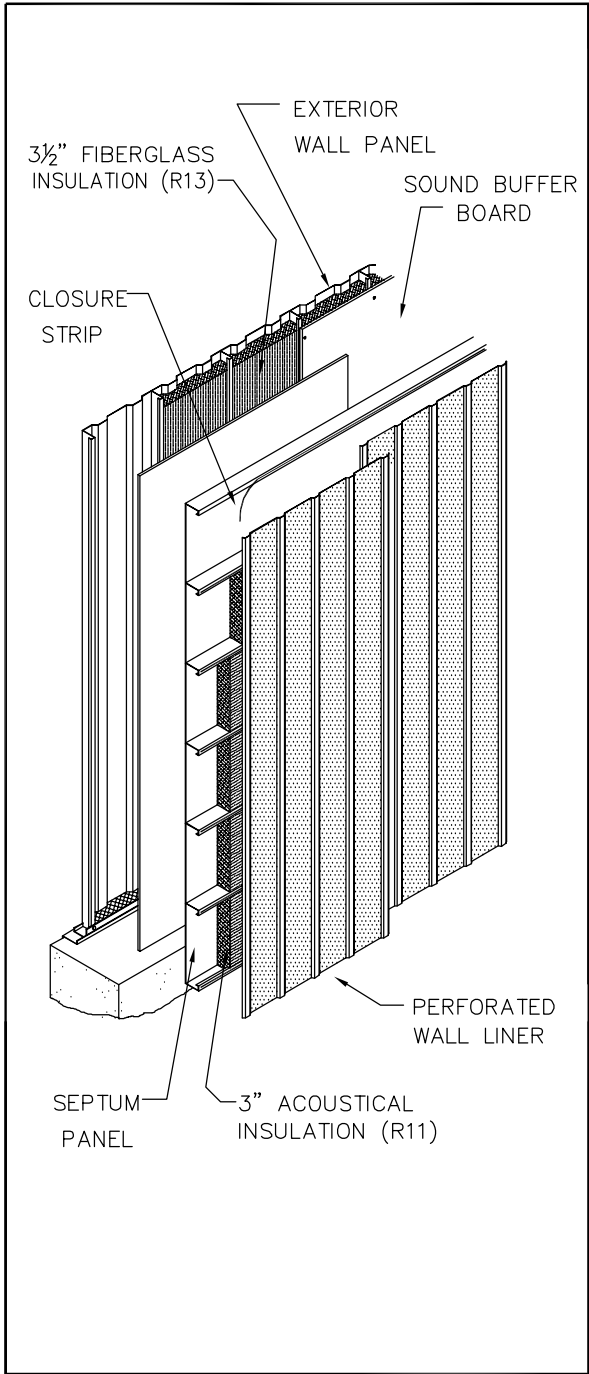

PRODUCT DESCRIPTION

A48 Acoustical Wall System

A48 Acoustical Wall System consists of a nominal 24 ga. fluted exterior panel with a minimum 16" wide, 3 1/2" thick, R-13, unfaced fiberglass, insulation in panel void. A 1/2" thick sound buffer board shall separate the exterior wall system and a nominal 26 ga. flush metal septum panel. The septum panels shall be installed perpendicular to the exterior wall panels with void filled with a minimum 16" wide, 3" thick, R-11, 4# density fibrous acoustical insulation. A vibration retardant tape will be installed between the septum panel ribs and a perforated formed liner panel. The system shall have an NRC of 1.00 and STC of 48. Wall accessories may effect overall performance.

This System has NOT been sound tested

Cavity Insulation	R 13
Continuous Insulation	R 0.45
Cavity Insulation	R 11

Calculated system "U" value 0.07 (ASHRAE zone method)

PRODUCT NAME

A48 Acoustical Wall System

MANUFACTURER

Parkline, Inc.
P.O. Box 65
Winfield, West Virginia 25213
Phone: (304) 586-2113 in WV
(800) 786-4855 outside WV
(304) 586-3842 FAX

web: <http://www.parkline.com>
E-mail: parkline@parkline.com

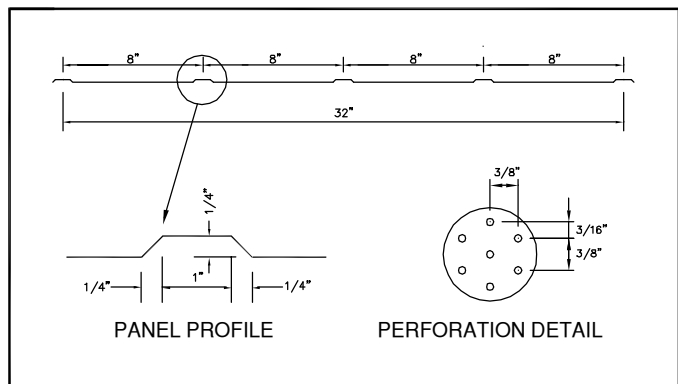

PARKLINE, INC.

13122 A48